



## Specifications

Interface	IEEE 802.3 1000BASE-T, IEEE 802.3af (PoE)
Resolution	2592 (H) × 1944 (V)
Sensor	ON Semi MT9P031 / MT9P006
Sensor type	CMOS
Shutter mode	Global reset and Rolling shutter
Sensor size	Type 1/2.5
Pixel size	2.2 μm × 2.2 μm
Lens mounts (available)	C-Mount, CS-Mount
Max. frame rate at full resolution	14 fps
ADC	12 Bit
Image buffer (RAM)	64 MByte

### Imaging performance

Imaging performance data is based on the evaluation methods in the EMVA 1288 Release 3.1 standard for characterization of image sensors and cameras. Measurements are typical values for monochrome models measured at full resolution without optical filter. Contact Sales or AE for more information.

Quantum efficiency at 529 nm	55 %
Temporal dark noise	7.5 e <sup>-</sup>
Saturation capacity	6000 e <sup>-</sup>
Dynamic range	57.6 dB
Absolute sensitivity threshold	8.0 e <sup>-</sup>

### Output

Bit depth	8/12 Bit
Monochrome pixel formats	Mono8, Mono12, Mono12Packed
YUV color pixel formats	YUV411Packed, YUV422Packed, YUV444Packed
RGB color pixel formats	RGB8Packed, BGR8Packed
Raw pixel formats	BayerGR8, BayerGR12Packed, BayerGR12



## Features

### Image control: Auto

- Auto exposure
- Auto gain
- Auto white balance (color models)

### Image control: Other

- Binning
- Black level
- Color transformation (incl. hue, saturation; color models)
- Decimation
- DPC (defect pixel correction)
- Gamma
- LUT (look-up table)
- Reverse X/Y
- ROI (region of interest)

### Camera control

- Acquisition frame rate
- Bandwidth control
- Event channel
- Firmware update in the field
- I/O and trigger control
- Image chunk data
- Stream hold
- Temperature monitoring
- ToE (trigger over Ethernet, action commands)
- User sets

## Technical drawing

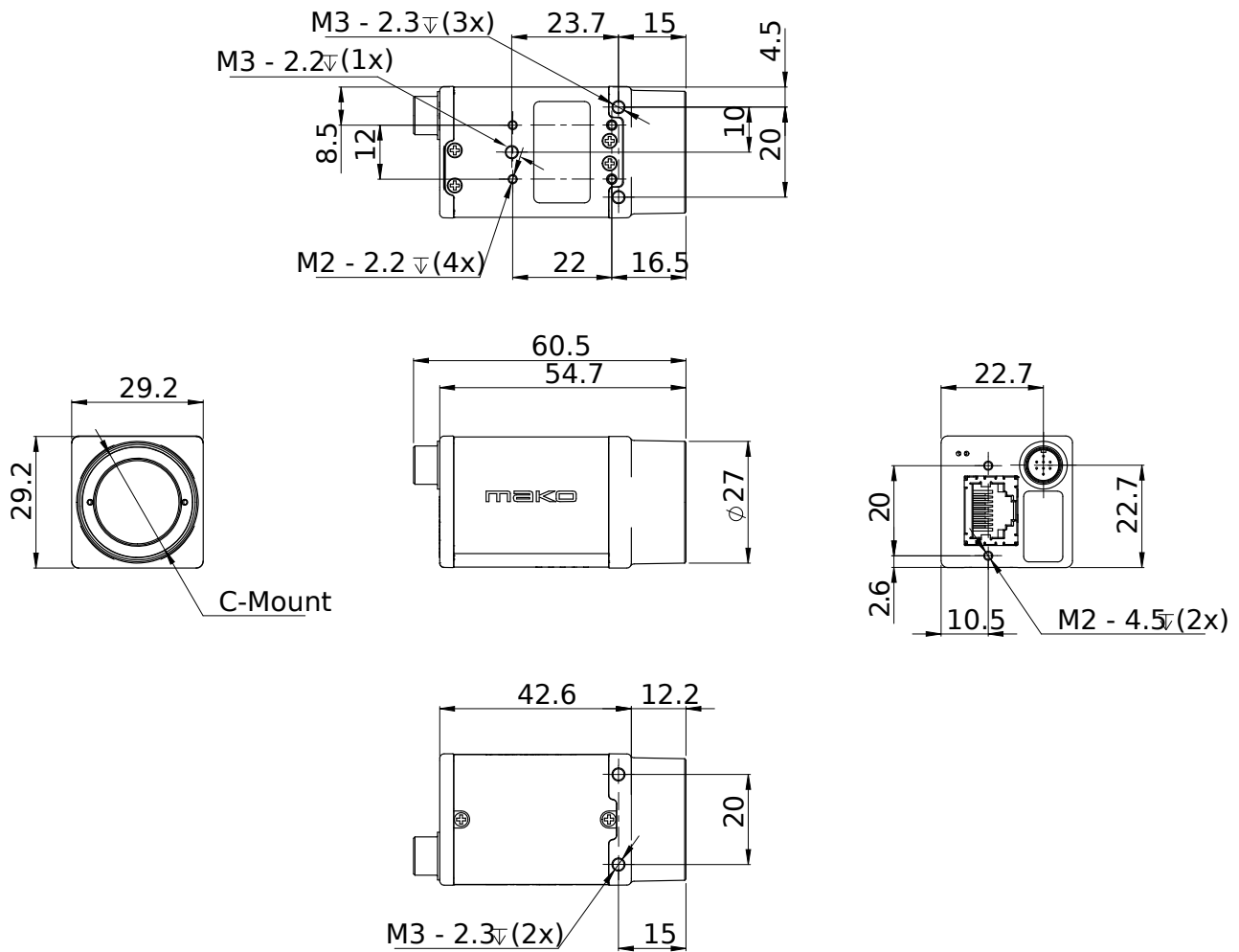

## Applications

Mako G is suitable for all typical applications in machine vision:

- Robotics
- Quality control
- Inspection, surveillance
- Industrial imaging
- Machine vision
- Logistics